

*On the Parameterization of Rational
Ringed Surfaces and Rational Canal
Surfaces*

B. Bastl, B. Jüttler, M. Lávička, T. Schulz, Z. Šír

Preprint no. 2014-08



On the Parameterization of Rational Ringed Surfaces and Rational Canal Surfaces

Bohumír Bastl¹, Bert Jüttler², Miroslav Lávička¹,
Tino Schulz³ and Zbyněk Šír^{1,4}

¹ *University of West Bohemia, Czech Republic*

² *Johannes Kepler University of Linz, Austria*

³ *INRIA Méditerranée, Sophia-Antipolis, France*

⁴ *Charles University in Prague, Czech Republic*

Abstract

Ringed surfaces and canal surfaces are surfaces that contain a one-parameter family of circles. Ringed surfaces can be described by a radius function, a directrix curve and vector field along the directrix curve, which specifies the normals of the planes that contain the circles. In particular, the class of ringed surfaces includes canal surfaces, which can be obtained as the envelopes of a one-parameter family of spheres. Consequently, canal surfaces can be described by a spine curve and a radius function. We present parameterization algorithms for rational ringed surfaces and rational canal surfaces. It is shown that these algorithms may generate any rational parameterization of a ringed (or canal) surface with the property that one family of parameter lines consists of circles. These algorithms are used to obtain rational parameterizations for Darboux cyclides and to construct blends between pairs of canal surfaces and pairs of ringed surfaces.

Keywords

Ringed surface, canal surface, rational parametrization, Darboux cyclide, Dupin cyclide, blending

1 Introduction

Rational parameterizations of curves and surfaces – in particular taking the form of NURBS (Non-Uniform Rational B-Splines) representations – are of fundamental importance in Computer Aided Geometric Design [10]. Indeed, these parameterizations form the basis of the many algorithms, e.g., for evaluation and plotting, offset computation, curve and surface interrogation, and for intersection computations, which are needed to manipulate and to visualize geometric objects. On the other hand, it is well known that most curves

and surfaces that can be described by algebraic equations do not possess a rational parameterization. The analysis of rational curves and surfaces is therefore of special interest for applications.

In this paper we will investigate the two classes of *rational ringed surfaces* and *rational canal surfaces*. The latter class of surfaces has been studied more thoroughly than the first one, see [9] and the references therein. They are defined as envelopes of one-parameter families of spheres in three-dimensional space. Special cases include pipe surfaces (obtained for spheres of constant radius) and surfaces of revolution (generated by spheres whose centers are located on a given line). Canal surfaces are used as blending surfaces between two given surfaces [2].

Any canal surface with a rational spine curve (which is the curve formed by the centers of the moving spheres) and a rational radius function admits a rational parameterization [19, 22]. An algorithm for generating rational parameterizations of canal surfaces was presented in [17]. The use of Pythagorean hodograph curves in the four-dimensional Minkowski space led to another approach for studying canal surfaces [5, 6]. Minimal rational parameterizations of canal surfaces were investigated in [14].

Dupin cyclides – which can be defined as the envelopes of all spheres touching three given spheres – form a very interesting class of canal surfaces [15]. They belong to the class of surfaces with Pythagorean normals (PN surfaces, see [23]), thus possessing rational offsets. Dupin cyclides were studied in geometric modeling due to their potential applications as blending surfaces [24, 26]. The use of Lie sphere geometry provides a convenient framework for analyzing their properties [4, 18].

The more general class of *ringed surfaces* is generated by sweeping a circle with variable radius – which is contained in a plane with a possibly non-constant normal vector – along a directrix curve [13]. By using circles in the normal plane of the directrix one obtains *normal ringed surfaces*, which again include pipe surfaces as a special case (obtained for constant radius). Any canal surface is a (generally non-normal) ringed surface. Ringed surfaces are well suited for designing pipe structures in plant modeling. Methods for connecting normal ringed surfaces were presented in [11, 28]. A special method for computing the intersection of two ringed surfaces is described in [12]. Rational surfaces with two families of circles are studied in [20].

The class of *Darboux cyclides* can be seen as a generalization of Dupin cyclides (which are special instances of canal surfaces) to the case of ringed surfaces. These surfaces have been studied in classical geometry [7, 8]. As one of the most interesting properties, these surface can carry up to six families of real circles [3, 27]. More recently, these surfaces have attracted attention from the geometric design community [16, 25], motivated by potential applications in architecture.

The present paper studies parameterization algorithms for rational ringed and canal surfaces in more detail. We introduce a unifying approach which is based on the fact that both classes of surfaces possess circles as parameter lines. All rational ringed surfaces resp. canal surfaces can be obtained from three resp. two given rational surface curves. In addition, several methods for parametrizing Darboux cyclides are discussed. As a possible application of the parameterization method, we will describe a construction of blending

surfaces.

The remainder of this paper is organized as follows. The next section summarizes several fundamental facts concerning ringed and canal surfaces and presents methods for their parameterization. Section 3 recalls existing results concerning Darboux cyclides, in particular concerning their relation to canal and ringed surfaces. The fourth section presents blending algorithms using canal and ringed surfaces.

2 Rational ringed surfaces and rational canal surfaces

We recall the notion of rational ringed surfaces. In addition we define rational canal surfaces as special instances of rational ringed surfaces.

Definition 1 *A rational surface*

$$\mathbf{x} : \mathbb{R}^2 \rightarrow \mathbb{R}^3 : (u, v) \mapsto \mathbf{x}(u, v)$$

*is said to be a **rational ringed surface** if*

- (i) *all parameter lines $v \mapsto \mathbf{x}(u_0, v)$, where $u_0 \in \mathbb{R}$ is a real constant, are circles.*

*Moreover, a rational ringed surface is called a **rational canal surface** if*

- (ii) *the envelope surface of the tangent planes along any of these circles is a circular cone or a cylinder.*

Note that this definition covers only ringed surfaces that possess a real rational parameterization with the property that one family of parameter lines are circles. The discussion of other rational ringed surfaces without such parameterizations is beyond the scope of the present paper.

The second property (ii) can be equivalently formulated as follows:

- (ii') *For each circle there exists a sphere that touches the surface along it.*

Indeed, the canal surface is the envelope of these spheres.

Each circle (i) on a rational ringed surface can be described by its center $\mathbf{c}(u)$, its radius $\varrho(u)$ and a (possibly non-unit) normal vector $\mathbf{n}(u)$ of the plane which contains the circle. Consequently, a rational ringed surface can be represented the curve $u \mapsto \mathbf{c}(u)$, the radius function $u \mapsto \varrho(u)$ and the vector field $u \mapsto \mathbf{n}(u)$ along the directrix. The curve \mathbf{c} and the vector field \mathbf{n} are called the *directrix* and the *normal vector field*, respectively.

In particular, if the vectors $\mathbf{n}(u)$ are tangent to the directrix, then we obtain a *normal ringed surface*, where all circles are contained in the directrix' normal planes.

Similarly, a canal surface can be described by the radius function $r(u)$ and centers $\mathbf{s}(u)$ of its enveloping spheres. The curve $u \mapsto \mathbf{s}(u)$ is called the *spine curve* of the canal surface.

Canal surfaces with constant radius function $r(u) = \text{const.}$ are called *pipe surfaces*. Equivalently, pipe surfaces can be characterized as *normal ringed surfaces* with *constant radius* function $\varrho(u) = \text{const.}$

Clearly, any canal surface is a ringed surface with

$$\mathbf{c}(u) = \mathbf{s}(u) - \frac{r(u)r'(u)}{\|\mathbf{n}(u)\|^2} \mathbf{n}(u), \quad \mathbf{n}(u) = \mathbf{s}'(u), \quad \text{and} \quad \varrho(t) = \frac{r(t)}{\|\mathbf{s}'(t)\|} \sqrt{\|\mathbf{s}'(t)\|^2 - r'(t)^2}. \quad (1)$$

On the other hand, a ringed surface is a canal surface if and only if

$$[(\mathbf{n} \cdot \mathbf{c}')\mathbf{c} + (\varrho\varrho')\mathbf{n}'] \times \mathbf{n} = \mathbf{0}. \quad (2)$$

Given a canal surface, by appending the radius function $r(u)$ to the points $\mathbf{s}(u) = (x(u), y(u), z(u))^\top$ of the spine curve, we obtain the *medial axis transform (MAT)*

$$u \mapsto (x(u), y(u), z(u), r(u))^\top \quad (3)$$

which is a curve in four-dimensional space. As proved in [17, 22], canal surfaces with rational MAT are rational. The proof of this fact relies on algorithms for decomposing a non-negative polynomial into a sum of two squares over \mathbb{R} . On the other hand rational canal surfaces with a non-rational MAT exist [21]. We provide a simple example.

Example 1 Consider the rational surface of revolution (which is therefore also a special canal surface)

$$\mathbf{x}(u, v) = \left(\frac{2(u^2 + 1)v}{1 + v^2}, \frac{(u^2 + 1)(1 - v^2)}{1 + v^2}, u \right)^\top, \quad (4)$$

generated by rotating the parabola $\mathbf{y}(u) = (0, u^2 + 1, u)^\top$ around the z -axis. The MAT is the planar algebraic curve

$$25 + 15r^2 + 66z^2 - 24r^4 - 60z^2r^2 + 57z^4 + 16z^6 - 16r^6 + 48z^2r^4 - 48z^4r^2 = 0 \quad (5)$$

in the rz -plane. It has genus 2 and is therefore non-rational.

Consequently, the class of rational canal surfaces with rational MAT is a proper subset of the class of rational canal surfaces.

Any rational canal surface has a rational spine curve $\mathbf{s}(u)$ and a rational squared radius function $r^2(u)$. After choosing two different values of v we find two rational curves $\mathbf{p}_1(u)$ and $\mathbf{p}_2(u)$ on the surface. By definition, for each u_0 there exists a sphere that is tangent to the surface and contains $\mathbf{p}_1(u_0)$ and $\mathbf{p}_2(u_0)$. Intersecting the surface normal at $\mathbf{p}_1(u_0)$ with the bisector plane of $\mathbf{p}_1(u_0)$ and $\mathbf{p}_2(u_0)$ gives the centers $\mathbf{s}(u)$ of the tangent spheres, i.e., the spine curve. Since $\mathbf{s}(u)$ is a rational curve, the squared distance function $r^2(u)$ is also rational. On the other hand, all canal surfaces with rational $\mathbf{s}(u)$ and $r^2(u)$ are rational [21, Section 6].

Similarly, any rational ringed surface possesses a rational directrix curve $\mathbf{c}(u)$, a rational normal vector field $\mathbf{n}(u)$ and a rational squared radius function $\varrho^2(u)$. Indeed, we may choose three fixed values for v and obtain three generic rational curves $\mathbf{p}_1(u)$, $\mathbf{p}_2(u)$, $\mathbf{p}_3(u)$. The centers $\mathbf{c}(u)$ of the circumcircles of the triangles $\Delta(\mathbf{p}_1\mathbf{p}_2\mathbf{p}_3)$ lie on a rational curve, which is the directrix of the ringed surface. Moreover, the squared distance of two points

on two rational curves (e.g. $\|\mathbf{p}_1(u) - \mathbf{c}(u)\|$) is rational. Vice versa, we can arrive at the conclusion that all ringed surfaces with rational $\mathbf{c}(u)$, $\mathbf{n}(u)$ and $\varrho^2(u)$ are rational. This result is based on the analogous considerations as for canal surfaces, cf. [21]. We construct a rational family of circles given by

$$\mathcal{C}(u) : \mathbf{n}(u)(\mathbf{x} - \mathbf{c}(u)) = (\mathbf{x} - \mathbf{c}(u))^2 - \varrho(u)^2 = 0, \quad (6)$$

corresponding birationally to some rational family of conics $\hat{\mathcal{C}}(u)$ in plane (obtained e.g. by the orthogonal projection to the xy -plane). Then using [21, Theorem 2.1] and stereographic projection, we obtain a quadratic parameterization of the conics in $\hat{\mathcal{C}}(u)$. a rational parameterization of the corresponding ringed surface can be generated by lifting the points back into space.

3 Parameterization of Rational Canal Surfaces

Given two rational curves $u \mapsto \mathbf{p}_1(u)$ and $u \mapsto \mathbf{p}_2(u)$ and a rational function $(u, v) \mapsto f(u, v)$, a parametrization of a canal surface interpolating both two curves can be obtained by the following algorithm.

PRCS: Algorithm for the Parameterization of Rational Canal Surfaces.

Input: Two rational curves \mathbf{p}_1 , \mathbf{p}_2 and a bivariate rational function f .

1: Generate the normal planes and the bisector plane of the two curves:

$$M : (\mathbf{X} - \mathbf{p}_1(u)) \cdot \mathbf{p}'_1(u) = 0, \quad (7)$$

$$N : (\mathbf{X} - \mathbf{p}_2(u)) \cdot \mathbf{p}'_2(u) = 0, \quad (8)$$

$$B : (2\mathbf{X} - \mathbf{p}_1(u) - \mathbf{p}_2(u)) \cdot (\mathbf{p}_1(u) - \mathbf{p}_2(u)) = 0. \quad (9)$$

2: Compute the intersection $\mathbf{s}(u)$ of these three planes.

3: Generate the parametrization of the surface from

$$\mathbf{x}(u, v) = \mathbf{s}(u) + \frac{(f(u, v) + \mathbf{s}'(u)) \star (\mathbf{p}_1(u) - \mathbf{s}(u)) \star (f(u, v) - \mathbf{s}'(u))}{(f(u, v) - \mathbf{s}'(u)) \star (f(u, v) + \mathbf{s}'(u))}. \quad (10)$$

Output: Parameterization $\mathbf{x}(u, v)$ of the corresponding canal surface.

Several aspects of this algorithm will be discussed in more detail:

- The intersection of the three planes in Step 2 generates the *spine curve* of the canal surface. Indeed, for any two curves on the canal surface, the corresponding point of the spine curve lies in the bisector plane and in the normal planes of the points on both curves, provided that points that possess the same parameter lie on one characteristic circle.

- In the third step of the algorithm, the sums $(f(v) \pm \mathbf{s}'(u))$ of scalars and vectors, as well as all vectors, are interpreted as *quaternions*, and \star denotes the *quaternion multiplication*

$$(a + \mathbf{a}) \star (b + \mathbf{b}) = ab - \mathbf{a} \cdot \mathbf{b} + a\mathbf{b} + b\mathbf{a} + \mathbf{a} \times \mathbf{b}. \quad (11)$$

The right-hand side of Eq. (10) is a quaternion with zero scalar part (a vector), hence the parameterization of the canal surface is well-defined.

- The second part of right-hand side in (10) describes a rotation of the vector $(\mathbf{p}_1(u) - \mathbf{s}(u))$ around the tangent of the curve $\mathbf{s}(u)$ by the angle θ , where

$$\tan \frac{\theta}{2} = \frac{f(u, v)}{\|\mathbf{s}'(u)\|}. \quad (12)$$

Thus, for any $u = u_0$ the rational function $f(u_0, v)$ determines a rational parameterization of the associated characteristic circle.

- One of the two curves can be replaced by a *line element*, i.e., by a point with an associated tangent vector. In this case, the normal plane of that curve is simply the constant plane through the given point which is orthogonal to the given tangent vector.

The analysis of the algorithm leads us to formulate the following result.

Theorem 1 *A rational surface is a rational canal surface if and only if it can be generated by the PRCS algorithm.*

Proof. First we show that any surface generated by PRCS is a rational canal surface. The spheres with center $\mathbf{s}(u)$ and radius $\|\mathbf{p}_1(u) - \mathbf{s}(u)\|$ touch both curves at the corresponding points. Consequently, the envelope of these spheres is a canal surface. Moreover, the characteristic circles generating this canal surface lie in planes with normal vectors $\mathbf{s}'(u)$, thus (10) is a rational parameterization of this canal surface.

Second we show that any rational canal surface (i.e., any parametrization of a rational canal surface) can be generated by PRCS. Consider a parametrization $\mathbf{x}(u, v)$ of a rational canal surface. We choose two rational curves $\mathbf{p}_1(u) = \mathbf{x}(u, v_0)$ and $\mathbf{p}_2(u) = \mathbf{x}(u, v_1)$ on this surface and use them to find the spine curve $\mathbf{s}(u)$, using the first two steps of the PRCS algorithm. Note that the identities

$$(\mathbf{x}(u, v) - \mathbf{p}_1(u)) \cdot \mathbf{s}'(u) = 0 \quad \text{and} \quad \|\mathbf{x}(u, v) - \mathbf{s}(u)\| = \|\mathbf{p}_1(u) - \mathbf{s}(u)\| \quad (13)$$

are automatically satisfied since $\mathbf{x}(u, v)$ is a rational canal surface. Now, using these observations and the definition of the quaternion product one can show that the two quaternions

$$\mathbf{x}(u, v) - \mathbf{p}_1(u) \quad \text{and} \quad \mathbf{s}'(u) \star (\mathbf{p}_1(u) - \mathbf{s}(u)) - (\mathbf{x}(u, v) - \mathbf{s}(u)) \star \mathbf{s}'(u) \quad (14)$$

are both vectors (quaternions with vanishing scalar part) and moreover linearly dependent for all $u, v \in \mathbb{R}$. Consequently, there exists a rational function $f(u, v)$ satisfying

$$f(u, v) \star (\mathbf{x}(u, v) - \mathbf{p}_1(u)) = \mathbf{s}'(u) \star (\mathbf{p}_1(u) - \mathbf{s}(u)) - (\mathbf{x}(u, v) - \mathbf{s}(u)) \star \mathbf{s}'(u). \quad (15)$$

Since the quaternion multiplication between scalars and quaternions is commutative, this equation is equivalent to

$$(\mathbf{x}(u, v) - \mathbf{s}(u)) \star (f(u, v) + \mathbf{s}'(u)) = (f(u, v) + \mathbf{s}'(u)) \star (\mathbf{p}_1(u) - \mathbf{s}(u)) \quad (16)$$

which can be rewritten as

$$\begin{aligned} \mathbf{x}(u, v) = \mathbf{s}(u) + (f(u, v) + \mathbf{s}'(u)) \star (\mathbf{p}_1(u) - \mathbf{s}(u)) \star \\ \star (f(u, v) - \mathbf{s}'(u)) \star (f(u, v) - \mathbf{s}'(u))^{-1} \star (f(u, v) + \mathbf{s}'(u))^{-1}. \end{aligned} \quad (17)$$

This completes the proof, as Equations (17) and (10) are identical. \square

It should be noted that PRCS generates not only all rational canal surfaces, but even *all possible rational parameterizations* for these surfaces.

We present a simple example where we apply the algorithm to two linear curves, i.e. to straight lines. Later we shall revisit this example, analyzing the remarkable properties of the resulting canal surface.

Example 2 Consider the two lines

$$\mathbf{p}_1(u) = \boldsymbol{\ell}_1(u) = (u, 0, 0)^\top, \quad \mathbf{q}_1(u) = \boldsymbol{\ell}_2(u) = (2u, u, 1)^\top. \quad (18)$$

Using PRCS, the corresponding spine curve is found to be

$$\mathbf{s}(u) = \left(u, 3u, \frac{1}{2} - 2u^2 \right)^\top \quad (19)$$

and by choosing simply $f(v) = v$ the algorithm generates the parametrization

$$\mathbf{x}(u, v) = \frac{1}{16u^2 + 10 + v^2} \begin{pmatrix} uv^2 - 12vu^2 - 4u - 3v \\ 48u^3 - 4vu^2 + 18u + v \\ 2(16u^2 - 3uv + 5) \end{pmatrix}. \quad (20)$$

Both lines and the canal surfaces are shown in Fig. 1.

4 Parameterization of Rational Ringed Surfaces

We shall now generalize the results of the previous section to the larger class of rational ringed surfaces. Given three rational curves $u \mapsto \mathbf{p}_i(u)$ ($i = 1, 2, 3$) and a rational function $(u, v) \mapsto f(u, v)$, a parametrization of a rational ringed surface interpolating these three curves can be obtained by the second algorithm.

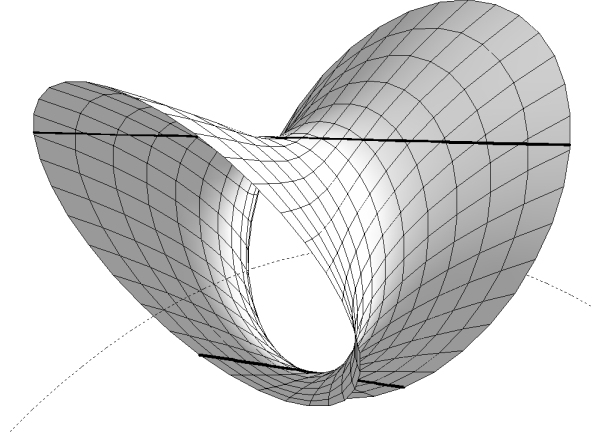

Figure 1: Applying PRCS to two lines (Example 2): The two given lines $\ell_1(u)$ and $\ell_2(u)$ (solid), the spine curve $\mathbf{s}(u)$ (dashed) and the obtained canal surface $\mathbf{x}(u, v)$ for $u \in [-\frac{1}{2}, \frac{1}{2}]$.

PRRS: Algorithm for the Parameterization of Rational Ringed Surfaces

Input: Three rational curves \mathbf{p}_1 , \mathbf{p}_2 , \mathbf{p}_3 and a bivariate rational function f .

1: Compute the normal vector

$$\mathbf{n}(u) = (\mathbf{p}_1(u) - \mathbf{p}_2(u)) \times (\mathbf{p}_1(u) - \mathbf{p}_3(u)).$$

2: Generate the plane through the three points and two of the bisector planes:

$$M : (\mathbf{X} - \mathbf{p}_1(u)) \cdot \mathbf{n}(u) = 0, \quad (21)$$

$$B_1 : (2\mathbf{X} - \mathbf{p}_1(u) - \mathbf{p}_2(u)) \cdot (\mathbf{p}_1(u) - \mathbf{p}_2(u)) = 0, \quad (22)$$

$$B_2 : (2\mathbf{X} - \mathbf{p}_1(u) - \mathbf{p}_3(u)) \cdot (\mathbf{p}_1(u) - \mathbf{p}_3(u)) = 0. \quad (23)$$

3: Compute the intersection $\mathbf{c}(u)$ of these three planes.

4: Generate the parametrization of the surface from

$$\mathbf{x}(u, v) = \mathbf{c}(u) + \frac{(f(u, v) + \mathbf{n}(u)) \star (\mathbf{p}_1(u) - \mathbf{c}(u)) \star (f(u, v) - \mathbf{n}(u))}{(f(u, v) + \mathbf{n}(u)) \star (f(u, v) - \mathbf{n}(u))} \quad (24)$$

Output: Parameterization $\mathbf{x}(u, v)$ of the corresponding ringed surface.

Some steps are similar to PRCS. There are, however, a few subtle differences:

- The intersection of the three planes generates the *directrix* of the ringed surface, i.e., the centers of the circles. The directrix $\mathbf{c}(u)$ is again a rational curve, but the radius function $\varrho(u) = \|\mathbf{p}_1(u) - \mathbf{c}(u)\|$ will be generally non-rational.
- One or two of the given curves can be replaced with points. In these situations, one obtains ringed surfaces where all circles pass through one or two fixed points.

The analysis of the algorithm leads us to formulate the following result.

Theorem 2 *A rational surface is a rational ringed surface if and only if it can be generated by PRRS.*

The proof is similar to the case of PRCS and can be omitted. Once again it should be noted that PRRS produces not only all rational ringed surfaces, but even *all possible rational parameterizations* for these surfaces

We present a simple example where we apply PRRS to one line and two points. Again we shall revisit this example later in order to analyze the properties of the rational ringed surface.

Example 3 Consider the line and the two points

$$\mathbf{p}_1(u) = \boldsymbol{\ell}_1(u) = (u, 0, 0)^\top, \quad \mathbf{p}_2(u) = \mathbf{P}_2 = (0, 0, 1)^\top \quad \text{and} \quad \mathbf{p}_3(u) = \mathbf{P}_3 = (1, 2, 1)^\top, \quad (25)$$

see Fig. 2. The computation of the directrix gives

$$\mathbf{c}(u) = \frac{1}{2(5 + 4u^2)} \begin{pmatrix} 4u^3 + 4u + 5 \\ 2(5 - u)(1 + u^2) \\ 3u^2 + 5u + 5 \end{pmatrix} \quad (26)$$

and by setting $f(v) = v$ the algorithm gives the following parametrization:

$$\mathbf{x}(u, v) = \frac{1}{v^2 + 5 + 4u^2} \begin{pmatrix} (u - 5 + v)(uv - 1) \\ 2(u - 5 + v)(1 + u^2) \\ 3u^2 + 5u - 2uv + 5v + 5 \end{pmatrix}. \quad (27)$$

Figure 2 shows the given data and the rational ringed surface which interpolates it.

5 Darboux cyclides

Darboux cyclides are a particularly interesting class of algebraic surfaces. We recall their definition and some of their properties.

As an informal definition, Darboux cyclides are rational surfaces of low degree that contain several families of circles. These cyclides were studied already in the 19th century. More recently, it has been observed that a Darboux cyclide may carry up to six different families of real circles [3, 27]. It is conjectured that any surface carrying at least three families of circles is a Darboux cyclide [25].

More precisely, a *Darboux cyclide* is defined by the implicit equation

$$D : \varphi_0 (\mathbf{X} \cdot \mathbf{X})^2 + \varphi_1 \mathbf{X} \cdot \mathbf{X} + \varphi_2 = 0 \quad (28)$$

where $\mathbf{X} = (x, y, z)^\top$. In this equation, φ_0 is a real constant, $\varphi_1 = c_x x + c_y y + c_z z$ is a homogeneous linear polynomial, and $\varphi_2 = \varphi_2(\mathbf{X})$ is a trivariate quadratic polynomial.

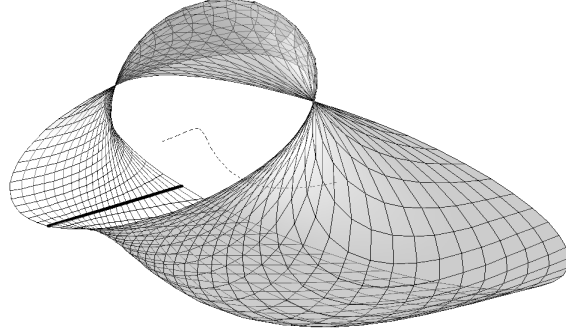

Figure 2: Applying PRRS to a line and two points (Example 3): The given line $\ell_1(u)$ (solid), the directrix $\mathbf{c}(u)$ (dashed) and the obtained ringed surface $\mathbf{x}(u, v)$ for $u \in [-2, 2]$ from Example 3. The two singularities are exactly the points \mathbf{P}_2 and \mathbf{P}_3 .

It is assumed that not all polynomials vanish simultaneously. Note that Dupin cyclides, quadrics and planes are special instances of Darboux cyclides.

In the following we will only consider real coefficients and coordinates and we will exclude Darboux cyclides with only complex points. Moreover, if not specified explicitly, we will only focus on Darboux cyclides whose defining equation is irreducible and of degree three or four, thus intersecting the absolute circle once or twice, respectively.

Darboux cyclides that satisfy the conditions $\varphi_0 = 0$ and $\varphi_1 \neq 0$ – and which are therefore algebraic surfaces of degree three – are called *parabolic*. Obviously, a Darboux cyclide with $\varphi_0 = \varphi_1 = 0$ is simply a quadric.

The class of Darboux cyclides is closed under Möbius transformations, in particular under inversions at spheres. If the center of the inversion sphere is located on the Darboux cyclide, then the equation of its image satisfies $\varphi_0 = 0$. Consequently, *it suffices to treat the computational issues associated with general Darboux cyclides – such as construction, classification and parameterization – for parabolic cyclides and quadrics only*. By using suitable Möbius transformations, the results can then easily be carried over to the general case.

Consider a parabolic Darboux cyclide D with a non-vanishing polynomial φ_1 , i.e., a parabolic Darboux cyclide which is not a quadric. The intersection of D with the plane at infinity therefore consists of the absolute circle and of a line ℓ_0 , which is determined by the linear polynomial φ_1 .

We consider the family of parallel planes which share the line ℓ_0 at infinity. Since D is a cubic surface, every plane containing ℓ_0 intersects D in a conic. It turns out that this conic may degenerate into a pair of real lines up to three times. Therefore, at most three pairs of lines on D in planes through ℓ_0 may be present.

Now consider the family of planes through one of these six lines. The intersections of D with these planes factors into the line and into *circles*, since the three intersection points with the plane at infinity are located on the line ℓ_0 and on the absolute circle. Consequently, each degenerate conic corresponds to a pair of circle families on D .

Takeuchi [27] shows that Darboux cyclides are covered by at least one family and at most six families of real circles. Consequently, the surface D is a ringed surface. It may happen that two of these families coincide. This happens exactly if one of the conics which are obtained by intersecting the planes through ℓ_0 with the Darboux cyclide degenerates into a *double line*. In this situation, the Darboux cyclide D is a canal surface. The canal surfaces among the Darboux cyclides carry at most 5 families of real circles.

In this situation, we shall refer to this degenerate conic as a *double line*. It should be noted that this is generally not a double curve in the usual sense, i.e., it does not consist of singular points of the surface D .

If another pair of lines is a double line, then the Darboux cyclide \hat{D} is a canal surfaces in two different ways. In this case, the surface \hat{D} becomes a parabolic Dupin cyclide which may carry up to four different families of circles.

We conclude this section with

Proposition 1 *Irreducible Darboux cyclides of degree three or four are rational ringed surfaces in the sense of Definition 1. Moreover, the canal surfaces among them are rational canal surfaces, again in the sense of Definition 1.*

Proof. We consider an irreducible parabolic Darboux cyclide D with a non-vanishing polynomial $\varphi_1(\mathbf{X})$ (recall that a general Darboux cyclide can be obtained from it by an inversion at some sphere). As observed before, D consists of a family of circles and thus it is a ringed surface. It remains to be shown that D possesses a rational parameterization with the property that one family of parameter lines consists of circles.

We consider the family of parallel planes passing through the line ℓ_0 at infinity, i.e.,

$$\varphi_1(\mathbf{X}) + u = 0, \quad u \in \mathbb{R}. \quad (29)$$

These planes intersect D in a rational family of conics $\mathcal{C}(u)$ given by (29) and

$$u(\mathbf{X} \cdot \mathbf{X}) - \varphi_2(\mathbf{X}) = 0. \quad (30)$$

The parameterization technique from [21] gives a method how to find for any fixed u_0 a rational parameterization $\mathbf{c}(u_0, v)$ of the conic $\mathcal{C}(u_0)$. Hence, $\mathbf{c}(u, v)$ is a rational parameterization of D . To sum up, D is a rational ringed surface and by Theorem 2 it can be generated by PRRS. Moreover, if D is a canal surface we can find a rational parameterization which can be generated by PRCS. \square

6 Constructing Darboux cyclides with many real circles

The special configuration of real lines on a parabolic Darboux cyclide D allows to formulate a simple construction for parabolic Darboux cyclides with many real families of circles:

DCMC: Algorithm for constructing Darboux Cyclides with Many real Circles

Input: Three mutually non-parallel lines ℓ_1, ℓ_2, ℓ_3 with a common normal \mathbf{n} .

- 1: Set $\varphi_0 = 0$ since the cyclide is parabolic.
- 2: Take $\varphi_1 = \mathbf{n} \cdot \mathbf{X}$. This determines the line at infinity which is hit by the three given lines.
- 3: The conditions that $\ell_i \subset D$ ($i = 1, 2, 3$) are formulated as a homogeneous system of linear equations for the coefficients of φ_2 , consisting of nine equations.
- 4: The quadratic trivariate polynomial φ_2 depends on ten parameters and it is therefore determined up to one free parameter α .
- 5: (optional: Apply an inversion at a sphere to transform the parabolic Darboux cyclide into a general one.)

Output: One-parameter family of parabolic Darboux cyclides through the three given lines (or through their images under the inversion at a sphere).

In addition to the given lines, the constructed surface contains up to three additional lines:

- In the generic case, this procedure generates a family of parabolic Darboux cyclides whose members carry six families of circles. Indeed, each intersection of the parabolic cyclide with one of the planes with normal \mathbf{n} through the given three lines factors into the line at infinity (with the equation $\varphi_1 = 0$), the line itself, and into another line.
- It turns out that the *direction* of the additional three lines is completely determined by the input specified in Step 1, but their *position* is controlled by the free parameter α . Thus, *only for special choices of the three given lines and of the free parameter α , one or two double lines on the cyclide will be created, which reduce the number of families of circles.*

The following example will illustrate the construction method and its properties.

Example 4 Consider the three lines

$$\ell_1(u) = (u, 0, 0)^\top, \ell_2(u) = (0, u, 1)^\top, \text{ and } \ell_3(u) = (u, u, 2)^\top, \quad u \in \mathbb{R}. \quad (31)$$

First we conclude that $\varphi_1(\mathbf{X}) = z$ since $\mathbf{n} = (0, 0, 1)^\top$. By requiring that the three given lines are on the cyclide, we determine nine of the ten parameters of $\varphi_2(\mathbf{X})$. The implicit equation of the parabolic Darboux cyclide is

$$C(x, y, z) = z(x^2 + y^2 + z^2) - y^2 - 4z^2 - 5xy + \alpha(2xz - 3yz + 3y) + 3z = 0, \quad (32)$$

where $\alpha \in \mathbb{R}$ is the free parameter. Moreover, we observe that

$$C(x, y, 0) = -y(5x + y - 3\alpha) = 0, \quad (33)$$

$$C(x, y, 1) = x(x - 5y + 2\alpha) = 0 \quad \text{and} \quad (34)$$

$$C(x, y, 2) = (x - y)(3x - 2y + 6\alpha) = 0. \quad (35)$$

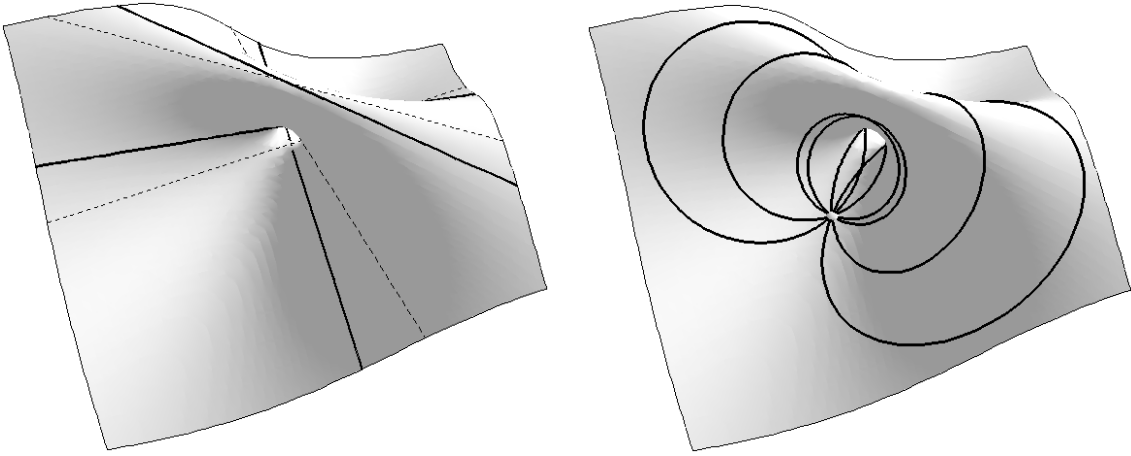

Figure 3: The parabolic Darboux cyclide C for $\alpha = 0$ from Example 4. Left: The three given lines ℓ_i ($i = 1, 2, 3$) (solid) and the additional three lines $\widehat{\ell}_i$ (dashed). Right: Six circles on the surface through the point $(2, -2, -1)^\top$.

This shows that the cyclide contains six different lines ℓ_1, ℓ_2, ℓ_3 and $\widehat{\ell}_1, \widehat{\ell}_2, \widehat{\ell}_3$, whose direction does not depend on α . Fig. 3 shows the cyclide and the six lines for $\alpha = 0$.

By applying an inversion at an arbitrary sphere to C we obtain a Darboux cyclide carrying six real families of circles.

7 Using PRCS for Darboux cyclides

This section studies the relation between DCMC, which generates the implicit equation of a Darboux cyclide, and PRCS, which computes rational parameterizations for canal surfaces. It is shown that both algorithms are closely related for simple input data. We begin our investigations in this section by analyzing a motivating example.

Example 2 (continued): Consider the canal surface C given by the rational parametrization $\mathbf{x}(u, v)$, see (20). The implicit equation of C is

$$4z(x^2 + y^2 + z^2) - 8y^2 - 3z^2 - 6xy - z = 0 \quad (36)$$

which confirms that C is a parabolic Darboux cyclide. By construction, C contains the two lines (18). We will now determine the remaining real lines on C . Since C is a cubic surface, any intersection with a plane through one of the constructed circles $\mathbf{x}(u_0, v)$ gives an additional line ℓ_3 on C . This line is independent of the choice of u_0 and lies on the hyperbolic paraboloid

$$(u, v) \mapsto (1 - v)\ell_1(u) + v\ell_2(u) \quad (37)$$

which is defined by $\ell_1(u)$ and $\ell_2(u)$. Direct computation shows that it can be written as

$$\ell_3(u) = \lambda\ell_1(u) + (1 - \lambda)\ell_2(u) = \frac{1}{4}(3u, -u, -1)^\top, \quad (38)$$

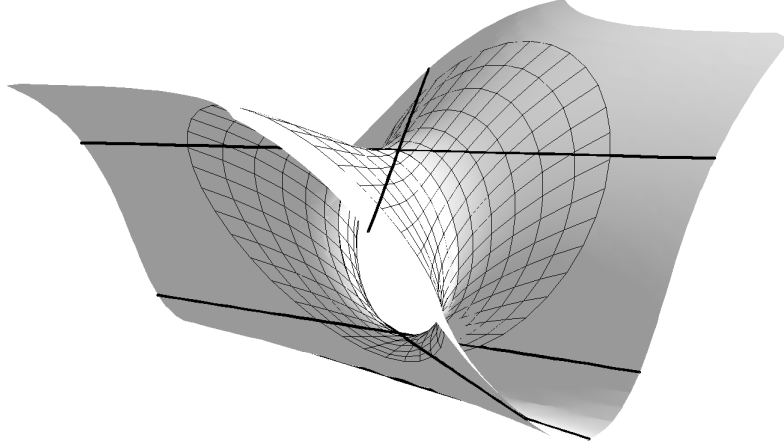

Figure 4: The algebraic surface C from Example 2 (continued) and the five real lines on it.

with

$$\lambda = \frac{\mathbf{w} \cdot \mathbf{w}}{\mathbf{w} \cdot \mathbf{w} - 1} = \frac{5}{4}, \quad (39)$$

where $\mathbf{w} = (2, 1, 0)^\top$ is the direction vector of ℓ_2 . Another real line ℓ_0 on C is the line at infinity of the planes $z = \text{constant}$, since the cubic terms of (36) factor into z and the absolute circle. Note that ℓ_0 intersects each of the three lines $\ell_i(u)$, $i = 1, 2, 3$. Hence, by intersecting C with the three planes $z = 0, z = 1$ and $z = -1/4$, which are spanned by the two lines ℓ_0 and ℓ_i , $i = 1, 2, 3$, we find additional real lines on C . It turns out that $\ell_3(u) = \widehat{\ell}_3(u)$ is a double line, while the two other lines can be parametrized by

$$\widehat{\ell}_1(u) = \left(u, -\frac{3}{4}u, 0\right)^\top \quad \text{and} \quad \widehat{\ell}_2(u) = (u, -2u, 1)^\top. \quad (40)$$

In addition to the line at infinity, we found five different real lines on C . Fig. 4 shows C and the five lines. Since C also contains the absolute circle, any generic plane through one of these five lines intersects C in a circle.

All findings of this example hold in the *general case*. Consider two skew, non-parallel, linearly parametrized lines

$$\ell_1(u) = \mathbf{P}_1 + u\mathbf{v}, \quad \ell_2(u) = \mathbf{P}_2 + u\mathbf{w}. \quad (41)$$

Since $\ell_1(u)$ and $\ell_2(u)$ are non-parallel, at least one of scalar products $(\mathbf{v} - \mathbf{w}) \cdot \mathbf{v}$ and $(\mathbf{v} - \mathbf{w}) \cdot \mathbf{w}$ is nonzero. Let us assume without loss of generality that $(\mathbf{v} - \mathbf{w}) \cdot \mathbf{v}$ is nonzero. Consequently there exists a value u_0 so that $(\ell_1(u_0) - \ell_2(u_0)) \cdot \mathbf{v} = 0$. Therefore after a similarity transformation and a simultaneous reparameterization of both lines, we can achieve that

$$\mathbf{P}_1 = (0, 0, 0)^\top, \quad \mathbf{v} = (1, 0, 0)^\top, \quad \mathbf{P}_2 = (0, 0, 1)^\top \quad \text{and} \quad \mathbf{w} = (a, b, c)^\top. \quad (42)$$

Using PRCS, the spine curve of the generated canal surface C is the parabola

$$\mathbf{s}(u) = \left(u, \frac{1}{2b} (c + 2(\mathbf{w} \cdot \mathbf{w} - a)u + c(\mathbf{w} \cdot \mathbf{w} - 1)u^2), \frac{1}{2} (1 + (1 - \mathbf{w} \cdot \mathbf{w})u^2) \right)^\top. \quad (43)$$

Note that $b \neq 0$ since the lines are skew. Moreover, if $\mathbf{w} \cdot \mathbf{w} = 1$ then $\mathbf{s}(u)$ degenerates into a line.

Before we continue, let us recall that a surface is called *Pythagorean-normal (PN) surface* if it possesses rational unit normals. Similarly, a parametrization is called *PN parametrization*, if it has the PN property.

Proposition 2 *Let C be the rational canal surface constructed from two lines $u \mapsto \mathbf{p}_1(u) = \ell_1(u)$ and $u \mapsto \mathbf{p}_2(u) = \ell_2(u)$ defined in (41) and (42). If $\mathbf{w} \cdot \mathbf{w} = 1$ then C is a hyperboloid of one sheet, otherwise it is a parabolic Darboux cyclide. In the latter case we can distinguish between two cases:*

- (I) $a = 1$: *The parabolic Darboux cyclide C carries four different families of circles (two possessing multiplicity two) and $\mathbf{x}(u, v)$ is PN. In this case, C is a parabolic Dupin cyclide.*
- (II) $a \neq 1$: *The parabolic Darboux cyclide C carries five different families of circles (one possessing multiplicity two) and $\mathbf{x}(u, v)$ is not PN.*

Proof. First let $\mathbf{w} \cdot \mathbf{w} = 1$. According to equation (43) the spine curve $\mathbf{s}(u)$ is now a line. The family of spheres given by

$$F(u) : (\mathbf{X} - \mathbf{s}(u)) \cdot (\mathbf{X} - \mathbf{s}(u)) - (\mathbf{s}(u) - \mathbf{p}_1(u)) \cdot (\mathbf{s}(u) - \mathbf{p}_1(u)) = 0 \quad (44)$$

is therefore only quadratic in x, y, z, u . Since C is the envelope of $F(u)$, direct computation shows that its implicit equation is also of degree two. Moreover, C contains a family of circles and two skew lines and thus it must be a hyperboloid of one sheet.

Now let $\mathbf{w} \cdot \mathbf{w} \neq 1$. Since $\mathbf{s}(u)$ is a parabola, C becomes a cubic surface of the form

$$(\mathbf{d}_1(\mathbf{w}) \cdot \mathbf{X})(\mathbf{X} \cdot \mathbf{X}) + \mathbf{X} \cdot (\mathbf{D}(\mathbf{w})\mathbf{X}) + \mathbf{d}_2(\mathbf{w}) \cdot \mathbf{X} = 0 \quad (45)$$

with $\mathbf{X} = (x, y, z)^\top$, $\mathbf{d}_1, \mathbf{d}_2 \in \mathbb{R}^3$ and $\mathbf{D} \in \mathbb{R}^{3 \times 3}$, which is a Darboux cyclide. Following the steps of the example, one always finds lines ℓ_3 and $\widehat{\ell}_1$. However, $\widehat{\ell}_2$ only differs from ℓ_2 if and only if $a \neq 1$. In that case, a direct computation shows that $\mathbf{x}(u, v)$ is not PN.

Otherwise, if $a = 1$, then ℓ_2 is a double line on C . If ℓ_3 and ℓ_2 are both double lines, then C is a canal surface in two different ways. Thus, $\mathbf{x}(u, v)$ is a parametrization of a Dupin cyclide and direct computation shows that it is also PN. \square

PRCS is closely related to DCMC. Indeed, we can easily specify the input for DCMC such that it gives the same Darboux cyclide as PRCS. In addition to $\ell_1(u)$ and $\ell_2(u)$ one just needs to pick $\ell_3(u)$ as defined by Eqs. (38) and (39). The free parameter which appears in DCMC is determined by the condition that $\ell_3(u)$ is a double line.

On the other hand, given a parabolic Darboux cyclide with at least three mutually skew lines, one of which is a double line, we can parameterize it using PRCS.

Proposition 3 *Any parabolic Darboux cyclide which is a canal surface and contains at least three mutually skew lines can be parameterized by applying PRCS to two linearly parameterized lines.*

Proof. The three lines lie in parallel planes, and one of them – which we assume to be the first one – is a double line. Consider the pencil of planes through the first line. Each plane of the pencil intersects the Darboux cyclide in a characteristic circle of the canal surface representation. We choose a linear parameterization of this pencil with a parameter u possessing the property that the limit plane obtained for $u \rightarrow \pm\infty$ is parallel to the remaining two lines. The intersection points of the pencil with the remaining two lines then provide two linear parameterizations for these lines. Applying PRCS to them gives a parameterization whose parameter lines are the characteristic circles of the given canal surface. \square

For the sake of completeness we also analyze the surfaces which are obtained by applying PRCS to a line and a line element. This discussion is postponed to Appendix A.

8 Using PRRS for Darboux cyclides

A natural question that naturally arises from the previous discussion is the following:

Does PRRS construct a parabolic Darboux cyclide when applied to three (linearly parametrized) lines?

Unfortunately, the answer is negative in general. However, we can specify additional conditions which imply the desired result.

Consider three non-parallel, linearly parametrized lines

$$\ell_i(u) = \mathbf{P}_i + u\mathbf{d}_i \quad (i = 1, 2, 3) \quad (46)$$

with a common normal \mathbf{n} . Thus the lines lie in three parallel planes P_1, P_2 and P_3 , all with normal \mathbf{n} . The PRRS algorithm constructs a family of circles which is contained in a family of planes Σ . We now derive conditions which guarantee that these circles form a parabolic Darboux cyclide.

The planes Σ form a *pencil* of non-parallel planes, i.e., they all intersect a common line ℓ_4 . Moreover, this line must lie on the cyclide, i.e., it is contained in a plane P_4 which is parallel to the planes P_i ($i = 1, 2, 3$). However, due to its construction, ℓ_4 cannot be in one of the planes of the first three lines. Thus without loss of generality we set $P_2 = P_1$. Additionally, we know that there must be a $u_0 \in \mathbb{R}$ such that $\ell_1(u_0) = \ell_2(u_0)$.

Taking these observations into account and after suitable coordinate transformations, we may choose

$$\ell_1(u) = u \begin{pmatrix} 1 \\ 0 \\ 0 \end{pmatrix}, \quad \ell_2(u) = u \begin{pmatrix} a_2 \\ b_2 \\ 0 \end{pmatrix}, \quad \text{and} \quad \ell_3(u) = \begin{pmatrix} x_3 \\ y_3 \\ 1 \end{pmatrix} + u \begin{pmatrix} a_3 \\ b_3 \\ 0 \end{pmatrix}, \quad (47)$$

with $b_2 \neq 0 \neq b_3$. With

$$\mathbf{n}(u) = (\boldsymbol{\ell}_1(u) - \boldsymbol{\ell}_2(u)) \times (\boldsymbol{\ell}_1(u) - \boldsymbol{\ell}_3(u)) \quad (48)$$

we can write the family of planes Σ , which carries the constructed family of circles, as

$$\Sigma : (\mathbf{X} - \boldsymbol{\ell}_1(u)) \cdot \mathbf{n}(u) = 0. \quad (49)$$

This family Σ is a pencil of non-parallel planes if and only if

$$a_2 \neq 1 \quad \text{and} \quad b_2(1 - a_3) - b_3(1 - a_2) \neq 0. \quad (50)$$

If the conditions of (50) are fulfilled, we can compute ℓ_4 , the generator of Σ . Now we can apply DCMC to the three lines ℓ_1, ℓ_3 and ℓ_4 and arrive at a one parameter family of parabolic Darboux cyclides.

A short computation confirms that there is exactly one member in this family of cyclides which also contains $\ell_2(u)$, if and only if

$$b_2(a_3^2 + b_3^2) - b_3(a_2^2 + b_2^2) + a_2b_3 - a_3b_2 = 0. \quad (51)$$

Summarizing, we get the following

Proposition 4 *If PRRS is applied to three lines as defined in (46) and (47), then the result is a parabolic Darboux cyclide if and only if the conditions (50) and (51) are satisfied.*

Note that if $\ell_2(u)$ and $\ell_3(u)$ do not fulfill (51), then they may do so after a linear reparameterization: Take for example $\ell_3(u)$ and replace \mathbf{d}_3 in equation (47) with $\mu \hat{\mathbf{d}}_3 = \mu(\hat{a}_3, \hat{b}_3, 0)^\top$. Solving this new expression for μ we can exclude the trivial solution $\mu = 0$ and get a unique value for μ .

On the other hand, given a parabolic Darboux cyclide with at least three mutually skew lines, we can parameterize it using PRRS.

Proposition 5 *Any parabolic Darboux cyclide which is a ringed surface and contains at least three mutually skew lines can be parameterized by applying PRRS to three linearly parameterized lines.*

Proof. The three lines lie in parallel planes. Moreover, the intersection of these planes with the Darboux cyclide gives additional three lines, which may be identical to the original three lines. At least one of them, however, does not coincide with the original lines. We assume that this is the case for the second given line and we will call this line the “additional line”.

Consider the pencil of planes through the first line. Each plane of the pencil intersects the Darboux cyclide in a circle of the ringed surface representation. We choose a linear parameterization of this pencil with a parameter u possessing the property that the limit plane obtained for $u \rightarrow \pm\infty$ is parallel to the remaining two lines. The intersection points of the pencil with the remaining two lines and with the additional line provide three linear

parameterizations for these lines. Applying PRRS to them gives a parameterization whose parameter lines are the circles of the given ringed surface. \square

There is again a close relation between PRRS and DCMC. Once a parabolic Darboux cyclide has been constructed with the help of DCMC, one can easily derive the input that is needed to obtain a parameterization from PRRS.

Example 5 Consider the three lines

$$\ell_1(u) = (u, 0, 0)^\top, \ell_2(u) = (2u, u, 0)^\top, \ell_3(u) = (1 - 2u, 1 + 4u, 1)^\top, \quad u \in \mathbb{R}. \quad (52)$$

We can easily check that conditions (50) are fulfilled but the condition (51) is not. Thus, instead of the direction vector $\mathbf{d}_3 = (-2, 4, 0)^\top$ we will consider $\hat{\mathbf{d}}_3 = \mu(-2, 4, 0)^\top$. By substituting $\hat{\mathbf{d}}_3$ to (51) we obtain the quadratic equation whose non-zero solution is $\mu = \frac{1}{2}$. Thus, we obtain another parameterization of the line ℓ_3 in the form

$$\hat{\ell}_3(u) = (1 - u, 1 + 2u, 1)^\top, \quad u \in \mathbb{R} \quad (53)$$

such that $\ell_1(u)$, $\ell_2(u)$, $\hat{\ell}_3(u)$ fulfill (50) and (51). Further, we can compute the generator of the family of planes of Σ

$$\ell_4(u) = (u, u, \frac{1}{4}). \quad (54)$$

Applying DCMC to the lines $\ell_1(u)$, $\hat{\ell}_3(u)$, $\ell_4(u)$ we obtain the one parametric family of parabolic Darboux cyclides with implicit equations

$$C_\alpha(x, y, z) = z(x^2 + y^2 + z^2) + \frac{1}{2}xy - y^2 + \alpha z^2 - \frac{1}{16}(34 + 8\alpha)xz - \frac{1}{8}(9 + 4\alpha)yz + \frac{1}{16}(13 + 4\alpha)y - \frac{1}{16}(1 + 4\alpha)z = 0, \quad \alpha \in \mathbb{R}. \quad (55)$$

Since (51) is fulfilled we can determine α such that $\ell_2(u)$ also lies on the cyclide. In particular, by substituting $\ell_2(u)$ to (55) we obtain the linear equation for α , providing $\alpha = -\frac{13}{4}$. Finally, we arrive at the implicit equation of the parabolic Darboux cyclide containing four lines $\ell_1(u)$, $\ell_2(u)$, $\hat{\ell}_3(u)$, $\ell_4(u)$

$$C(x, y, z) = z(x^2 + y^2 + z^2) + \frac{1}{2}(xy - xz + yz) - y^2 - \frac{13}{4}z^2 + \frac{3}{4}z = 0. \quad (56)$$

Moreover, we observe that

$$\begin{aligned} C(x, y, 0) &= \frac{1}{2}(x - 2y)y = 0, \\ C(x, y, 1) &= \frac{1}{2}(1 + x)(-3 + 2x + y) = 0, \\ C(x, y, \frac{1}{4}) &= \frac{1}{8}(x - y)(-1 + 2x + 6y). \end{aligned} \quad (57)$$

This shows that the the cyclide contains the lines $\ell_1(u)$, $\ell_2(u)$, $\hat{\ell}_3(u)$, $\ell_4(u)$ and two additional lines

$$\ell_5(u) = (-1, u, 1)^\top, \ell_6(u) = \left(\frac{1}{2} - 3u, u, \frac{1}{4}\right)^\top. \quad (58)$$

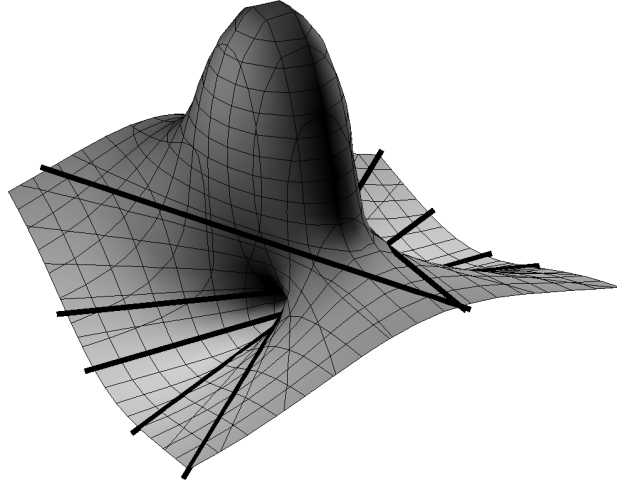

Figure 5: The parabolic Darboux cyclide C from Example 5 with six real lines on it.

In order to find the parameterization of the Darboux cyclide (56) we can apply PRRS algorithm to the three lines $\ell_1(u)$, $\ell_2(u)$, $\hat{\ell}_3(u)$. The computation of the directrix gives

$$\mathbf{c}(u) = \frac{1}{2 + 16u^2} (-3u + 4u^2 + 8u^3, 7u - 4u^2 + 24u^3, 3 - 2u + 8u^2), \quad (59)$$

and by setting $f(u, v) = v$ the PRRS algorithm gives the following parameterization

$$\mathbf{x}(u, v) = \frac{1}{2u^2 + 16u^4 + v^2} \begin{pmatrix} -8u^3 + 8u^4 + 3uv - 2u^2v + 12u^3v + uv^2 \\ 14u^3 - 8u^4 + 48u^5 + 3uv - 2u^2v + 4u^3v \\ 6u^2 - 4u^3 + 16u^4 - 2u^2v \end{pmatrix}. \quad (60)$$

Fig. 5 shows the given lines and the corresponding rational ringed surface.

For the sake of completeness we also analyze the surfaces which are obtained by applying PRRS to a line and two points. This discussion is postponed to Appendix B.

9 Blending

Blending is one of the most important operations in geometric design. The main purpose of this operation is to generate one or more surfaces that create a smooth connection between the given shapes. In what follows we will pay a special attention to blending with canal and ringed surfaces using the approach presented in the previous sections.

9.1 Blending with canal surfaces

In this section we will show how PRCS can be used for blending two given canal surfaces with a canal surface.

Consider two segments of canal surfaces C_i ($i = 1, 2$) both given by parameterizations $(u, v) \mapsto \mathbf{x}_i(u, v)$, and let k_i be their end characteristic circles. Let $K \geq 2$ be a positive integer. A blending canal surface, joined to the given canal surfaces with smoothness of class C^{K-2} and G^{K-1} , can be constructed by the following procedure:

- (i) Choose four points $\mathbf{P}_{ij} = \mathbf{x}_i(u_i, v_{ij})$ on the two end circles k_i ($i, j = 1, 2$) and generate the associated derivative vectors

$$\mathbf{t}_{ij}^{(k)} = \left(\frac{\partial^k \mathbf{x}_i}{\partial u^k} \right) (u_i, v_{ij}), \quad k = 1, \dots, K.$$

Here, we assume that the second parameter of \mathbf{x}_i has been used to parametrize the circles on both canal surfaces.

- (ii) Compute two C^K smooth rational or piecewise rational curves $\mathbf{p}_j(u)$ ($j = 1, 2$) that interpolate the two boundary points and the associated K derivatives at both end points.
- (iii) Find a parameterization of a blending canal surface determined by the two curves $u \mapsto \mathbf{p}_j(u)$ using PRCS.

The smoothness of the blending is ensured by the following

Proposition 6 *Assume that the inputs $\mathbf{p}_1(u)$, $\mathbf{p}_2(u)$ and $f(u, v)$ of PRCS are piecewise rational and C^k smooth where $k > 1$. Then the resulting piecewise rational canal surface $\mathbf{x}(u, v)$ has the geometric smoothness G^{k-1} .*

Proof. The computation of $\mathbf{s}(u)$ is rational in $\mathbf{p}_1(u)$, $\mathbf{p}_2(u)$ and its derivatives. Consequently, the spline curve $\mathbf{s}(u)$ is C^{k-1} smooth. The formula producing the rational parametrization $\mathbf{x}(u, v)$ contains also $\mathbf{s}'(u)$, hence $\mathbf{x}(u, v)$ is generally only C^{k-2} . However, since the family of implicitly defined spheres whose envelope defines the canal surface is C^{k-1} , one can show that the envelope surface is in fact still G^{k-1} smooth. It suffices to prove this for the envelope of a family of circles in the plane, since one can simply intersect the canal surface with a plane. We consider the envelope curve of a family of circles which are defined implicitly by the equations

$$F(\mathbf{x}, v) = 0$$

that depend on the parameter $v \in \mathbb{R}$. The equations are C^{k-1} smooth with respect to v and C^∞ with respect to the coordinates \mathbf{x} . The parameterization of the envelope curve satisfies

$$F(\mathbf{x}(v), v) = 0 \quad \text{and} \quad F_2(\mathbf{x}(v), v) = 0,$$

where F_2 denotes the derivative with respect to the second argument (i.e., v). Differentiating the first equation $k - 1$ times with respect to v gives an equation of the form

$$(\nabla F)(\mathbf{x}(v), v) \cdot \mathbf{x}^{(k-1)}(v) + [\dots] = 0 \tag{61}$$

where the term in square brackets depends only on derivatives of order less than $k - 1$. Now we consider two segments of the envelope, which are obtained for two adjacent rational segments of the two given input curves. We consider the difference of the one-sided limits of equation (61). The difference between the derivative vectors of \mathbf{x} of order $k - 1$ is then necessarily parallel to the tangent vector of the curve, since the terms in brackets are identical for both segments. Using the definition of geometric continuity [10] one can now verify that the envelope is G^{k-1} . \square

Although PRCS is useful for parameterizing canal surfaces, the blending method based on this algorithm has some shortcomings. The main drawback is that it is very difficult to generate curves $\mathbf{p}_1, \mathbf{p}_2, u \in I$ such that the associated planes M, N are never (close to) parallel in the whole interval I . Consequently, it is quite hard to control the shape of the blend. In addition, the obtained surface is generally only G^{K-1} smooth, but one needs derivatives of order K to generate it.

9.2 Blending with ringed surfaces

The modification for blending with ringed surfaces is obvious – one simply computes three points with the associated derivative vectors on k_1 and k_2 which determine three curves as input curves into PRRS.

A blending ringed surface joined to given ringed surfaces C_1, C_2 given by parameterizations $\mathbf{x}_1(u, v), \mathbf{x}_2(u, v)$, respectively, along prescribed end circles k_1, k_2 with G^1 continuity can be constructed by the following steps:

Consider two segments of ringed surfaces C_i ($i = 1, 2$) both given by parameterizations $(u, v) \mapsto \mathbf{x}_i(u, v)$, and let k_i be their end characteristic circles. Let $K \geq 1$ be a positive integer. A blending canal surface, joined to the given canal surfaces with smoothness of class C^K , can be constructed by the following procedure:

- (i) Choose four points $\mathbf{P}_{ij} = \mathbf{x}_i(u_i, v_{ij})$ on the two end circles k_i ($i = 1, 2; j = 1, 2, 3$) and generate the associated derivative vectors

$$\mathbf{t}_{ij}^{(k)} = \left(\frac{\partial^k \mathbf{x}_i}{\partial u^k} \right) (u_i, v_{ij}), \quad k = 1, \dots, K.$$

Again assume that the second parameter of \mathbf{x}_i has been used to parametrize the circles on both ringed surfaces.

- (ii) Compute two C^K smooth rational or piecewise rational curves $\mathbf{p}_j(u)$ ($j = 1, 2, 3$) that interpolate the two boundary points and the associated K derivatives at both end points.
- (iii) Find a parametrization of a blending ringed surface determined by the three curves $\mathbf{p}_1(u), \mathbf{p}_2(u), \mathbf{p}_3(u)$ using PRRS.

The smoothness of the blending is ensured by the following

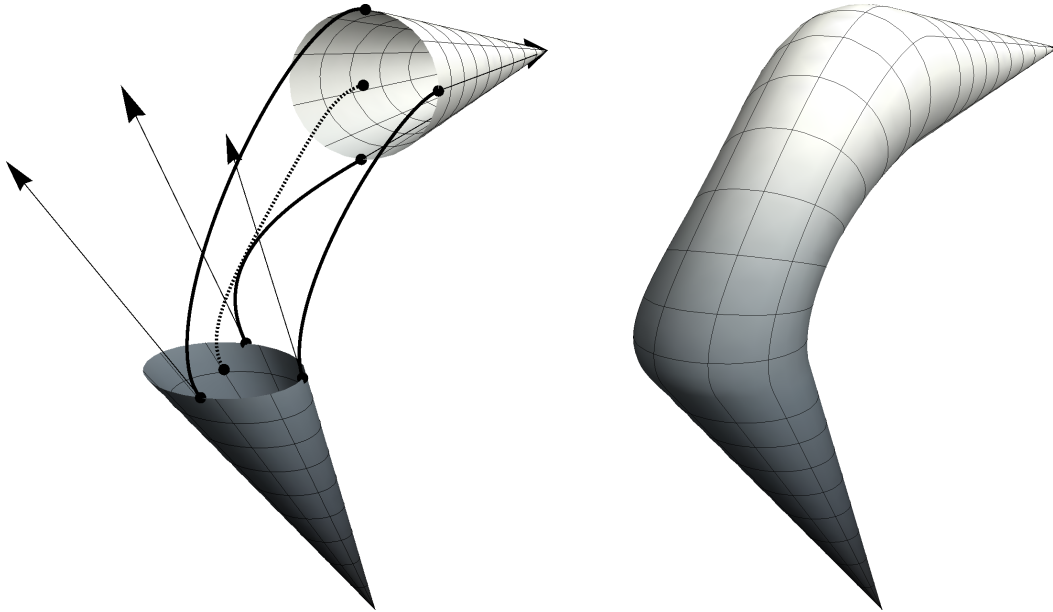

Figure 6: Left: Two given ringed surfaces (quadratic cones), three cubic curves interpolating sampled data (solid) and the computed directrix curve (dashed); Right: The final blending ringed surface.

Proposition 7 *Assume that the inputs $\mathbf{p}_1(u)$, $\mathbf{p}_2(u)$, $\mathbf{p}_3(u)$ and $f(u, v)$ of PRRS are C^K smooth and piecewise rational where $K \geq 1$. Then the resulting piecewise rational ringed surface $\mathbf{x}(u, v)$ is also C^K smooth.*

Proof. The successive computation of $\mathbf{n}(u)$, $\mathbf{c}(u)$ and $\mathbf{x}(u, v)$ does not involve any differentiation and requires only rational operations. Hence the constructed surface has the smoothness C^k . \square

Fig. 6 shows an example of a C^1 -smooth blending ringed surface obtained by this procedure for two chosen ringed surfaces.

Compared to the blending method based on PRCS, the technique for blending with ringed surfaces is more robust, as the choice of the three curves $\mathbf{p}_j(u)$ allows a better control of the shape of the constructed ringed surface. Moreover, we obtain a C^K smooth blending surface when using derivatives of order K .

10 Conclusion

This paper was devoted to rational parameterizations of ringed and canal surfaces. These surfaces possess circles as parameter lines. All parameterizations can be obtained from three or two given rational curves by using two simple algorithms. Moreover, we observed that parabolic Darboux cyclides appear naturally among the most simple examples of our parameterization method, thereby allowing to construct parameterizations for surfaces with many real circles. As a second possible application we used the parameterization

algorithms for constructing blend surfaces. We observed that ringed surfaces are better suited for blending than canal surface when using our two algorithms.

Acknowledgments T. Schulz was supported by the Marie-Curie Network SAGA (FP7, GA no. 214584), and by the Doctoral Program “Computational Mathematics” (W1214) at Johannes Kepler University, Linz. B. Bastl and M. Lávička were supported by the European Regional Development Fund (ERDF), project “NTIS – New Technologies for Information Society”, European Centre of Excellence, CZ.1.05/1.1.00/02.0090. All authors were supported by the Austrian/Czech project KONTAKT 7AMB12AT012.

Appendix A: Canal surfaces generated by a line and a line element

The construction of Section 7 can be further simplified by considering just a line element $(\mathbf{P}_2, \mathbf{n})$ instead of a line as second curve. The second normal plane in the PRCS algorithm then becomes constant. Similar to the setting in the previous section, we consider without loss of generality

$$\boldsymbol{\ell}_1(u) = (u, 0, 0)^\top \quad \text{and} \quad \mathbf{p}_2(u) = \mathbf{P}_2 = (0, 0, 1)^\top. \quad (62)$$

Moreover, we can set

$$\mathbf{n} = (a, 1, c)^\top \quad (63)$$

since \mathbf{n} needs to be linearly independent of $\{(1, 0, 0)^\top, (0, 0, 1)^\top\}$. The spine curve

$$\mathbf{s}(u) = \left(u, \frac{1}{2}(c(1 - u^2) - 2au), \frac{1}{2}(1 + u^2) \right)^\top, \quad (64)$$

is now always a parabola. We will skip the parametrization $\mathbf{x}(u, v)$ and proceed directly to the implicit equation

$$C(x, y, z) = (cy - z)(x^2 + y^2 + z^2) + (1 - a^2 - c^2)y^2 + 2axy + 2(z^2 - cy - z) = 0, \quad (65)$$

of the surface which confirms that the PRCS algorithm produces again a parabolic Darboux cyclide.

First we notice that the line at infinity of C is $z = cy$. Thus by observing that

$$C(x, y, cy) = y(2xa + (1 - a^2 + c^2)y - 2c) = 0 \quad \text{and} \quad (66)$$

$$C(x, y, cy + 1) = -(x - ay)^2 = 0 \quad (67)$$

we can find either one ($a = c = 0$) or two ($a \neq 0 \neq c$) additional lines on the surface. Note that one of these lines is $\widehat{\boldsymbol{\ell}}_2(u) = \mathbf{P}_2 + u\mathbf{n}$ and that it is always a double line. Using similar arguments as in the previous section we can formulate the following result.

Proposition 8 *Let C be the rational canal surface obtained by applying the PRCS algorithm to the lines $\boldsymbol{\ell}_1(u)$ and the line element $(\mathbf{P}_2, \mathbf{n})$ defined in (62) and (63). C is a parabolic Darboux cyclide with a singularity at \mathbf{P}_2 . We can distinguish between two cases:*

(I) $a = c = 0$: The parabolic Darboux cyclide C carries two different families of circles (both possessing multiplicity two) and $\mathbf{x}(u, v)$ is PN. In this case, C is a parabolic Dupin cyclide.

(II) $a \neq 0 \neq c$: The parabolic Darboux cyclide C carries three different families of circles (one of multiplicity two) and $\mathbf{x}(u, v)$ is not PN.

Proof. Most properties follow from direct computation. The line $\widehat{\ell}_2(u) = \mathbf{P}_2 + u\mathbf{n}$ is always a double line. If $a = 0 = c$ then $\ell_1(u)$ is also a double line and thus C becomes a Dupin cyclide, guaranteeing that $\mathbf{x}(u, v)$ is PN as any rational parameterization of any Dupin cyclide is PN. This follows from the fact that for any Dupin cyclide there exists a proper parameterization which is PN (obtained e.g. from a PN proper parameterization of a torus by a spherical inversion); hence any proper parameterization $\mathbf{x}(s, t)$ of any Dupin cyclide is PN (see [1], Corollary 3.4.) and thus any rational parameterization $\mathbf{x}(u, v)$ of any Dupin cyclide gained from $\mathbf{x}(s, t)$ by a rational reparameterization $(s, t) = (\varphi_1(u, v), \varphi_2(u, v))$ is PN. \square

Appendix B: Ringed surfaces generated by a line and two points

We shall begin our investigations by analyzing a motivating example.

Example 3 (continued): Consider the canal surface C given by the rational parametrization $\mathbf{x}(u, v)$, see (27). Implicitization of (27) yields

$$C : 4z(x^2 + y^2 + z^2) - 3y^2 - 8z^2 - 4xy - 10yz + 10y + 4z = 0, \quad (68)$$

which describes a Darboux cyclide. Since C is a cubic surface, any intersection with a plane through one of the constructed circles $\mathbf{x}(u_0, v)$ gives an additional line $\widehat{\ell}_2$ on C . This line passes through \mathbf{P}_2 and \mathbf{P}_3 and therefore we can parametrize it as

$$\widehat{\ell}_2(u) = u\mathbf{P}_2 + (1 - u)\mathbf{P}_3 = (1 - u, 2(1 - u), 1)^\top. \quad (69)$$

Moreover, the surface C also contains the infinite line ℓ_0 of the planes $z = \text{constant}$. The intersection of C with the plane $z = 1$ gives the double line $\widehat{\ell}_2(u)$, and the intersection with the plane $z = 0$ factors into ℓ_1 and the additional real line

$$\widehat{\ell}_1(u) = \left(u, \frac{1}{3}(10 - 4u), 0 \right)^\top. \quad (70)$$

In addition to the line at infinity, we found three different real lines on C . Fig. 7 shows C and all three lines. Since C also contains the absolute circle, any generic plane through one of these three lines intersects C in a circle.

All findings of this examples hold in the *general case*. Consider a linearly parametrized line and two points:

$$\ell_1(u) = \mathbf{P}_1 + uv, \quad \mathbf{p}_2(u) = \mathbf{P}_2 \quad \text{and} \quad \mathbf{p}_3(u) = \mathbf{P}_3, \quad (71)$$

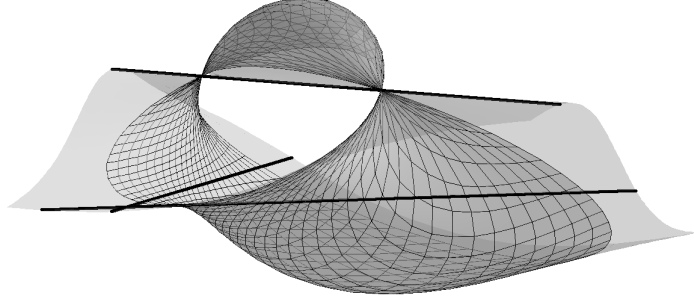

Figure 7: The algebraic surface C from Example 3 (continued) and the three real lines on it.

which do not lie in one plane. Through the use of similarity transformations (i.e., translation, rotation, scaling) and a reparameterization we may transform the given data into

$$\mathbf{P}_1 = (0, 0, 0)^\top, \quad \mathbf{v} = (1, 0, 0)^\top, \quad \mathbf{P}_2 = (0, 0, 1)^\top \quad \text{and} \quad \mathbf{P}_3 = (a, b, c)^\top. \quad (72)$$

The geometric properties of the result of the PRRS algorithm is summarized in

Proposition 9 *Let C be the rational ringed surface constructed from the line ℓ_1 and from the points $\mathbf{P}_2, \mathbf{P}_3$ defined in (71) and (72). Then C is parabolic Darboux cyclide which possesses singularities at \mathbf{P}_2 and \mathbf{P}_3 . We can distinguish between two cases:*

- (I) $a = 0$ and $b^2 + c^2 = 1$: The parabolic Darboux cyclide C carries two different families of circles (both of multiplicity two) and $\mathbf{x}(u, v)$ is PN. In this case, C is a parabolic Dupin cyclide.
- (II) $a \neq 0$ or $b^2 + c^2 \neq 1$: The parabolic Darboux cyclide C carries three different families of circles (one of multiplicity two) and $\mathbf{x}(u, v)$ is not PN.

Proof. The line through \mathbf{P}_2 and \mathbf{P}_3 is a double line and thus C is also a canal surface. If moreover $a = 0$ and $b^2 + c^2 = 1$ then ℓ_1 is also a double line and C becomes a Dupin cyclide. Direct computation shows that $\mathbf{x}(u, v)$ is PN if and only if this is the case. \square

The PRRS algorithm is again closely related to the DCMC algorithm. Indeed we can specify the input of the DCMC algorithm (and modify it slightly) so that it produces the same parabolic Darboux cyclide as the PRRS algorithm. Indeed, the first line is ℓ_1 and the second line is the line through \mathbf{P}_2 and \mathbf{P}_3 . Unfortunately, there is no obvious choice for the third line. However, the corresponding parabolic Darboux cyclide is also uniquely defined and can be found by solving a linear system if one requires that it contains the line ℓ_1 and possesses singularities at the two given points.

Moreover, it is also possible to detect certain similarities to the example from Appendix A. By considering the limit case of $\mathbf{P}_2 \rightarrow \mathbf{P}_3$ with

$$\frac{\mathbf{P}_2 - \mathbf{P}_3}{\|\mathbf{P}_2 - \mathbf{P}_3\|} \parallel (a, 1, c)^\top \quad (73)$$

we can relate both constructions with each other. In fact, since canal surfaces are special ringed surfaces, using PRCS for a line and a line element can be seen as a limit case of the PRRS Algorithm for a line and two points.

References

- [1] E. Arrondo, J. Sendra, and J. R. Sendra. Parametric generalized offsets to hypersurfaces. *Journal of Symbolic Computation*, 23:267–285, 1997.
- [2] B. Bastl, B. Jüttler, M. Lávička, and T. Schulz. Blends of canal surfaces from polyhedral medial surface transform representations. *Computer-Aided Design Design*, 43(11):1477–1484, 2011.
- [3] R. Blum. Circles on surfaces in the Euclidean 3-space. In *Geometry and Differential Geometry*, volume 792 of *Lecture Notes in Mathematics*, pages 213–221. Springer Berlin / Heidelberg, 1980.
- [4] A. Bobenko and E. Huhnen-Venedey. Curvature line parametrized surfaces and orthogonal coordinate systems: discretization with Dupin cyclides. *Geometriae Dedicata*, pages 1–31, 2011. 10.1007/s10711-011-9653-5.
- [5] H.Ch. Cho, H.I. Choi, S.-H. Kwon, D.S. Lee, and N.-S. Wee. Clifford algebra, Lorentzian geometry and rational parametrization of canal surfaces. *Computer Aided Geometric Design*, 21:327–339, 2004.
- [6] H.I. Choi and D.S. Lee. Rational parametrization of canal surface by 4 dimensional Minkowski Pythagorean hodograph curves. In *Proceedings of the Geometric Modeling and Processing 2000, GMP '00*, pages 301–309, Washington, DC, USA, 2000. IEEE Computer Society.
- [7] J.L. Coolidge. *A Treatise on the Circle and Sphere*. Clarendon Press, 1916.
- [8] J.G. Darboux. Sur le contact des courbes et des surfaces. *Bulletin des Sciences Mathématiques*, 2(4):348–384, 1880.
- [9] M. Dohm and S. Zube. The implicit equation of a canal surface. *J. Symb. Comput.*, 44:111–130, February 2009.
- [10] G. Farin, J. Hoschek, and M.-S. Kim, editors. *Handbook of Computer Aided Geometric Design*. Elsevier, 2002.
- [11] E. Hartmann. G^n -continuous connections between normal ringed surfaces. *Computer Aided Geometric Design*, 18(8):751 – 770, 2001.
- [12] H.-S. Heo, S.J. Hong, J.-K. Seong, M.-S. Kim, and G. Elber. The intersection of two ringed surfaces and some related problems. *Graphical Models*, 63:228–244, 2001.
- [13] J.K. Johnstone. A new intersection algorithm for cyclides and swept surfaces using circle decomposition. *Computer Aided Geometric Design*, 10(1):1 – 24, 1993.
- [14] R. Krasauskas. Minimal rational parametrizations of canal surfaces. *Computing*, 79:281–290, April 2007.
- [15] R. Krasauskas and C. Mäurer. Studying cyclides with Laguerre geometry. *Computer Aided Geometric Design*, 17(2):101–126, 2000.
- [16] R. Krasauskas and S. Zube. Bézier-like parametrizations of spheres and cyclides using geometric algebra. In K. Guerlebeck, editor, *9th International Conference on Clifford Algebras and their Applications in Mathematical Physics*, 2011. <http://www.mif.vu.lt/~rimask/en/>.
- [17] G. Landsmann, J. Schicho, and F. Winkler. The parametrization of canal surfaces and the decomposition of polynomials into a sum of two squares. *Journal of Symbolic Computation*, 32(1-2):119 – 132, 2001.

- [18] M. Lávička and J. Vršek. On the representation of Dupin cyclides in Lie sphere geometry with applications. *Journal for Geometry and Graphics*, 13(2):145–162, 2009.
- [19] W. Lü and H. Pottmann. Rational parameterization of quadrics and their offsets. *Computing*, 57:135–147, 1996.
- [20] N. Lubbes. Families of circles on surfaces. arXiv:1302.6710, 2013.
- [21] M. Peternell. Rational families of conics and quadrics. In *The Mathematics of Surfaces*, volume VIII, pages 369–382. Information Geometers, 1998.
- [22] M. Peternell and H. Pottmann. Computing rational parametrizations of canal surfaces. *Journal of Symbolic Computation*, 23:255–266, February 1997.
- [23] H. Pottmann. Rational curves and surfaces with rational offsets. *Computer Aided Geometric Design*, 12(2):175–192, 1995.
- [24] H. Pottmann and M. Peternell. Applications of Laguerre geometry in CAGD. *Computer Aided Geometric Design*, 15:165–186, 1998.
- [25] H. Pottmann, L. Shi, and M. Skopenkov. Darboux cyclides and webs from circles. *Computer Aided Geometric Design*, 29(1):77 – 97, 2012.
- [26] C.-K. Shene. Blending two cones with Dupin cyclides. *Computer Aided Geometric Design*, 15(7):643 – 673, 1998.
- [27] N. Takeuchi. Cyclides. *Hokkaido Mathematical Journal*, 29(1):119, 2000.
- [28] P. Zhou and W.-H. Qian. Blending multiple parametric normal ringed surfaces using implicit functional splines and auxiliary spheres. *Graphical Models*, 73(4):87 – 96, 2011.